Chapter 5

BMX AMI 0810 Analog Input Module

Subject of this Chapter

This chapter presents the BMX AMI 0810 module, its characteristics, and explains how it is connected to the various sensors.

What Is in This Chapter?

This chapter contains the following topics:

Topic	Page
Presentation	108
Characteristics	109
Functional Description	111
Wiring Precautions	118
Wiring Diagram	121
Use of the TELEFAST Wiring Accessories	122

Presentation

Function

The BMX AMI 0810 is a high density input analog module with 8 isolated channels.

This module is used in conjunction with sensors or transmitters; it performs monitoring, measurement, and continuous process control functions.

The BMX AMI 0810 module offers the following range for each input according to the selection made during configuration:

- Voltage +/-5 V/+/-10 V/0..5 V/0..10 V/1..5 V
- Current +/-20 mA/0..20 mA/4..20 mA

The module operates with voltage inputs. It includes eight read resistors connected to the terminal block to perform current inputs.

Ruggedized Version

The BMX AMI 0810H (hardened) equipment is the ruggedized version of the BMX AMI 0810 (standard) equipment. It can be used at extended temperatures and in harsh chemical environments.

For more information, refer to chapter *Installation in More Severe Environments (see Modicon M580, M340, and X80 I/O Platforms, Standards and Certifications)*.

Illustration

The following graphic shows the BMX AMI 0810 analog input module:

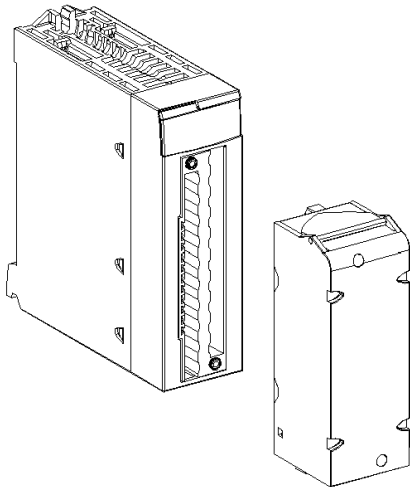

NOTE: The terminal block is supplied separately.

Characteristics

Altitude Operating Conditions

The characteristics in the tables below apply to the modules BMX AMI 0810 and BMX AMI 0810H for use at altitude up to 2000 m (6560 ft). When the modules operate above 2000 m (6560 ft), apply additional derating.

For detailed information, refer to chapter *Operating and Storage Conditions* (see *Modicon M580, M340, and X80 I/O Platforms, Standards and Certifications*).

General Characteristics

The general characteristics for the BMX AMI 0810 and BMX AMI 0810H modules are as follows:

Operating temperature	BMX AMI 0810	0...60 °C (32...140 °F)
	BMX AMI 0810H	-25...70 °C (-13...158 °F)
Type of inputs	High level isolated fast inputs	
Nature of inputs	Voltage / Current	
Number of channels	8	
Acquisition cycle time:		
<ul style="list-style-type: none"> Fast (periodic acquisition for the declared channels used) 		1 ms + 1 ms x number of channels used
<ul style="list-style-type: none"> Default (periodic acquisition for all channels) 		9 ms
Display resolution	16-bit	
Digital filtering	First order	
Isolation:		
<ul style="list-style-type: none"> Between channels 		+/-300 VDC
<ul style="list-style-type: none"> Between channels and bus 		1400 VDC
<ul style="list-style-type: none"> Between channels and ground 		1400 VDC
Maximum overload authorized for inputs:	Voltage inputs: +/- 30 VDC Current inputs: +/- 30 mA Protected against accidental wiring: -19.2 to 30VDC NOTE: The Protected for accidental wiring function is not supported when the module works with any Telefast interface.	
Power consumption (3.3 V)	Typical	0.32 W
	Maximum	0.48 W
Power consumption (24 V)	Typical	1.06 W
	Maximum	1.50 W

Measurement Range

The BMX AMI 0810 and BMX AMI 0810H analog inputs have the following measurement range characteristics:

Measurement range	+/- 10 V; +/- 5 V 0...10 V; 0...5 V; 1...5 V	+/- 20 mA; 0...20 mA; 4...20 mA
Maximum conversion value	+/-11.4 V	+/-30 mA
Conversion resolution	0.36 mV	1.4 µA
Input impedance	10 MΩ	Internal conversion resistor (250 Ω) + Internal protection resistor (see note)
Precision of the internal conversion resistor	-	0.1% - 15 ppm/°C
Measurement errors for standard module :		
<ul style="list-style-type: none"> At 25°C Maximum in the temperature range 0...60°C (32...140°F) 	0.075% of FS ⁽¹⁾ 0.1% of FS ⁽¹⁾	Typical 0.15% of FS ⁽¹⁾⁽²⁾ 0.3% of FS ⁽¹⁾⁽²⁾
Measurement errors for Hardened module:		
<ul style="list-style-type: none"> At 25°C Maximum in the temperature range - 25...70°C (-13...158°F) 	0.075% of FS ⁽¹⁾ 0.2% of FS ⁽¹⁾	Typical 0.15% of FS ⁽¹⁾⁽²⁾ 0.55% of FS ⁽¹⁾⁽²⁾
Temperature drift	30 ppm/°C	50 ppm/°C
Monotonicity	Yes	Yes
Common mode rejection (50/60 Hz)	80 dB	80 dB
Crosstalk between channels DC and AC 50/60Hz	> 80 dB	> 80 dB
Non-linearity	0.001%	0.001%
Repeatability @25°C of 10 min. stabilization time	0.005% of FS ⁽¹⁾	0.007% of FS ⁽¹⁾
Long term stability after 1000 hours	< 0.004% of FS ⁽¹⁾	< 0.004% of FS ⁽¹⁾
(1) FS: Full Scale (2) With conversion resistor error		

NOTE: The internal protection resistor has a typical impedance of 25 Ω (min 3.6 Ω and max 50 Ω). The precision of the protection resistor does not impact the measured value.

NOTE: If nothing is connected on a BMX AMI 0810 and BMX AMI 0810H analog module and if channels are configured (range 4...20 mA or 1...5 V), there is a detected I/O error as if a wire is broken.

Functional Description

Function

The BMX AMI 0810 is a high density input analog module with 8 isolated channels.

This module is used in conjunction with sensors or transmitters; it performs monitoring, measurement, and continuous process control functions.

The BMX AMI 0810 module offers the following range for each input according to the selection made during configuration:

- +/-10 V
- 0..10 V
- 0..5 V / 0..20 mA
- 1..5 V / 4..20 mA
- +/-5 V / +/-20 mA

The module operates with voltage inputs. It includes eight read resistors connected to the terminal block to perform current inputs.

Illustration

The BMX AMI 0810 illustration:

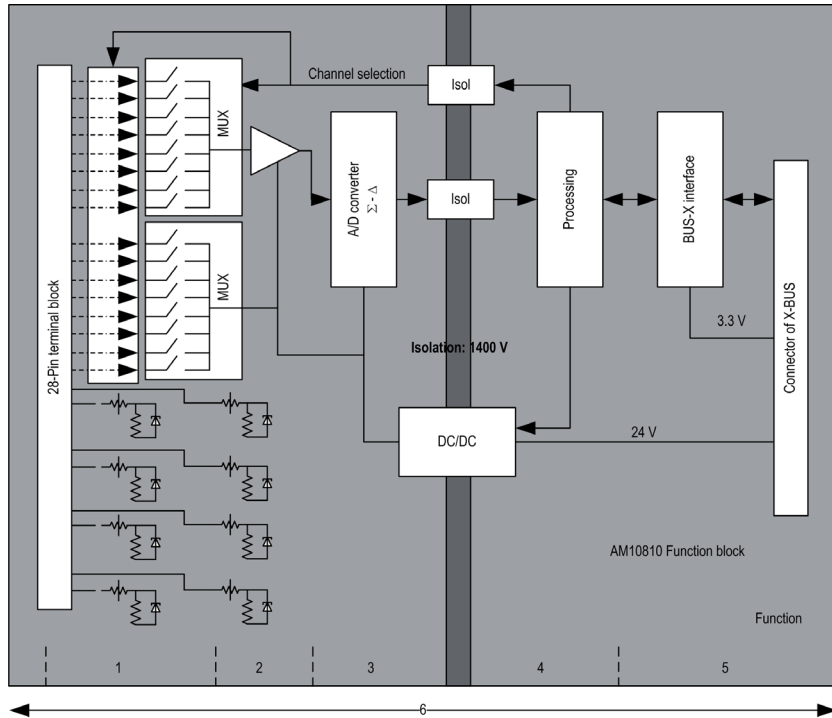

Description:

No.	Process	Function
1	Adapting the Inputs and Multiplexing	<ul style="list-style-type: none"> Physical connection to the process through a 28-pin screw terminal block Protection of the module against overvoltages Protection of the current reading resistors using limiters and resettable fuses Input signal analog filtering Scan input channels using static multiplexing through opto-switches, in order to provide the possibility of common mode voltage of +/- 300 Vdc
2	Amplifying Input Signals	<ul style="list-style-type: none"> Gain selecting , based on characteristics of input signals, as defined during configuration (unipolar or bipolar range, in voltage or current) Compensation of drift in amplifier device
3	Converting	<ul style="list-style-type: none"> Conversion of analog Input signal into digital 24-bit signal using a $\Sigma\Delta$ converter

No.	Process	Function
4	Transforming incoming values into workable measurements for the user.	<ul style="list-style-type: none"> • Takes into account recalibration and alignment coefficients to be applied to measurements and the module's self-calibration coefficients • (Numeric) filtering fo measurements, based on configuration parameters • Scaling of measurements, based on configuration parameters
5	Communicating with the Application	<ul style="list-style-type: none"> • Manages exchanges with CPU • Topological addressing • Receives configuration parameters from module and channels • Sends measured values, as well as module status, to application
6	Module monitoring and sending error notification back to application.	Conversion string test Testing for range overflow on channels Watchdog test

Measurement Timing

The timing of measurements is determined by the cycle selected during configuration (Normal or Fast Cycle):

- Normal Cycle means that the scan cycle duration is fixed.
- With the Fast Cycle, however, the system only scans the channels designated as being In Use. The scan cycle duration is therefore proportional to the number of channels In Use.

The cycle time values are based on the cycle selected:

Module	Normal Cycle	Fast Cycle
BMX AMI 0810	9 ms	1 ms + (1 ms x N) where N: number of channels in use.

NOTE: Module cycle is not synchronized with the PLC cycle. At the beginning of each PLC cycle, each channel value is taken into account. If the MAST/FAST task cycle time is less than the module's cycle time, some values will not have changed.

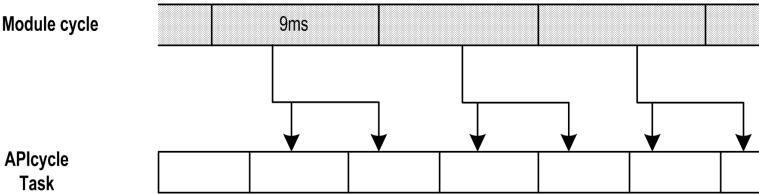

Overflow/Underflow Control

Module BMX AMI 0810 allows the user to select between 6 voltage or current ranges for each input.

This option for each channel have to be configured in configuration windows. Upper and lower tolerance detection are always active regardless of overflow/underflow control.

Depending on the range selected the module checks for overflow, it verifies that the measurement falls between a lower and an upper threshold:

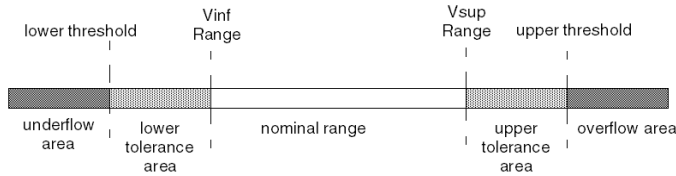

Description:

Designation	Description
Nominal range	measurement range corresponding to the chosen range
Upper Tolerance Area	varies between the values included between the maximum value for the range (for instance: +10 V for the +/-10 V range) and the upper threshold
Lower Tolerance Area	varies between the values included between the minimum value for the range (for instance: -10 V for the +/-10 V range) and the lower threshold
Overflow Area	area located beyond the upper threshold
Underflow Area	area located below the lower threshold

The values of the thresholds are configurable independently from one another. They may assume integer values between the following limits:

Range	BMX AMI 0810 Range									
	Underflow Area		Lower Tolerance Area		Nominal Range		Upper Tolerance Area		Overflow Area	
Unipolar										
0...10 V	-1,500	-1,001	-1,000	-1	0	10,000	10,001	11,000	11,001	11,400
0...5 V / 0...20 mA	-5,000	-1,001	-1,000	-1	0	10,000	10,001	11,000	11,001	15,000
1...5 V / 4...20 mA	-4,000	-801	-800	-1	0	10,000	10,001	10,800	10,801	14,000
Bipolar										
+/- 10 V	-11,500	-11,001	-11,000	-10,001	-10,000	10,000	10,001	11,000	11,001	11,400
+/- 5 V, +/- 20 mA	-15,000	-11,001	-11,000	-10,001	-10,000	10,000	10,001	11,000	11,001	15,000

Range	BMX AMI 0810 Range									
	Underflow Area		Lower Tolerance Area		Nominal Range		Upper Tolerance Area		Overflow Area	
User										
+/- 10 V	-32,768				User-defined	User-defined				32,767
0...10 V	-32,768				User-defined	User-defined				32,767

Measurement Display

Measurements may be displayed using standardized display (in %, to two decimal places):

Type of Range	Display
Unipolar range 0...10 V, 0...5 V, 1...5 V, 0...20mA, 4...20mA	from 0 to 10,000 (0 % at +100.00 %)
Bipolar range +/- 10 V, +/- 5 mV +/- 20 mA	from -10,000 to 10,000 (-100.00 % at +100.00 %)

It is also possible to define the range of values within which measurements are expressed, by selecting:

- the lower threshold corresponding to the minimum value for the range: 0 % (or -100.00 %).
- the upper threshold corresponding to the maximum value for the range (+100.00 %).

The lower and upper thresholds must be integers between -32,768 and +32,767.

For example, imagine a conditioner providing pressure data on a 4-20 mA loop, with 4 mA corresponding to 3,200 millibar and 20 mA corresponding to 9,600 millibar. You have the option of choosing the User format, by setting the following lower and upper thresholds:

3,200 for 3,200 millibar as the lower threshold

9,600 for 9,600 millibar as the upper threshold

Values transmitted to the program vary between 3,200 (= 4 mA) and 9,600 (= 20 mA).

Measurement Filtering

The type of filtering performed by the system is called "first order filtering". The filtering coefficient can be modified from a programming console or via the program.

The mathematical formula used is as follows:

$$Meas_{f(n)} = \alpha \times Meas_{f(n-1)} + (1 - \alpha) \times Val_{b(n)}$$

where:

α = efficiency of the filter

$Meas_{f(n)}$ = measurement filtered at moment n

$Meas_{f(n-1)}$ = measurement filtered at moment n-1

$Val_{b(n)}$ = gross value at moment n

You may configure the filtering value from 7 possibilities (from 0 to 6). This value may be changed even when the application is in RUN mode.

NOTE: Filtering may be accessed in Normal or Fast Cycle.

The filtering values depend on the T configuration cycle (where T = cycle time of 5 ms in standard mode):

Desired Efficiency	Required Value	Corresponding α	Filter Response Time at 63%	Cut-off Frequency (in Hz)
No filtering	0	0	0	0
Low filtering	1	0.750	4 x T	0.040 / T
	2	0.875	8 x T	0.020 / T
Medium filtering	3	0.937	16 x T	0.010 / T
	4	0.969	32 x T	0.005 / T
High filtering	5	0.984	64 x T	0.0025 / T
	6	0.992	128 x T	0.0012 / T

Sensor Alignment

The process of "alignment" consists in eliminating a systematic offset observed with a given sensor, around a specific operating point. This operation compensates for an error linked to the process. Replacing a module does not therefore require a new alignment. However, replacing the sensor or changing the sensor's operating point does require a new alignment.

Conversion lines are as follows:

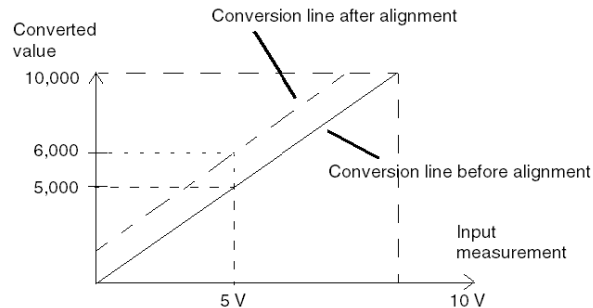

The alignment value is editable from a programming console, even if the program is in RUN Mode. For each input channel, you can:

- view and modify the desired measurement value
- save the alignment value
- determine whether the channel already has an alignment

The alignment offset may also be modified through programming.

Channel alignment is performed on the channel in standard operating mode, without any effect on the channel's operating modes.

The maximum offset between measured value and desired (aligned) value may not exceed +/- 1.500.

NOTE: To align several analog channels on the BMX ART/AMO/AMI/AMM modules, we recommend proceeding channel by channel. Test each channel after alignment before moving to the next channel in order to apply the parameters correctly.

Wiring Precautions

Introduction

In order to protect the signal from outside interference induced in series mode and interference in common mode, we recommend that you take the following precautions.

Cable Shielding

Connect the cable shielding to the grounding bar. Clamp the shielding to the grounding bar on the module side. Use the shielding connection kit BMXXSP**** (see page 48) to connect the shielding.

⚠ DANGER

HAZARD OF ELECTRIC SHOCK, EXPLOSION, OR ARC FLASH

While mounting / removing the modules:

- make sure that each terminal block is still connected to the shield bar and
- disconnect voltage supplying sensors and pre-actuators.

Failure to follow these instructions will result in death or serious injury.

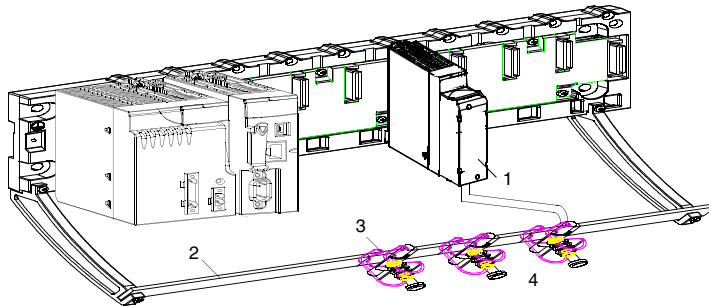

- 1 BMX AMI 0810
- 2 Shield bar
- 3 Clamp
- 4 To sensors

Reference of Sensors in Relation to the Ground

In order for the acquisition system to operate correctly, it is recommended to take in account the following precautions:

- sensors must be close together (a few meters)
- all sensors must be referenced to a single point, which is connected to the PLC's ground

Using the Sensors Referenced in Relation to the Ground

The sensors are connected as indicated in the following diagram:

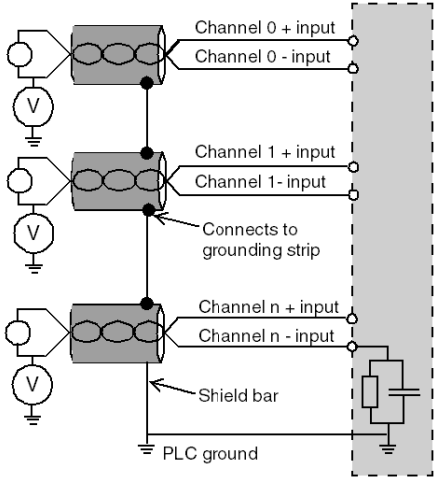

If the sensors are referenced in relation to the ground, this may in some cases return a remote ground potential to the terminal block. It is therefore **essential** to follow the following rules:

- The potential must be less than the permitted low voltage: for example, 30 Vrms or 42.4 VDC.
- Setting a sensor point to a reference potential generates a leakage current. You must therefore check that all leakage currents generated do not disturb the system.

NOTE: Sensors and other peripherals may be connected to a grounding point some distance from the module. Such remote ground references may carry considerable potential differences with respect to local ground. Induced currents do not affect the measurement or integrity of the system.

⚠ DANGER

HAZARD OF ELECTRIC SHOCK

Ensure that sensors and others peripherals are not exposed through grounding points to voltage potential greater than acceptable limits.

Failure to follow these instructions will result in death or serious injury.

Electromagnetic Hazard Instructions

CAUTION

UNEXPECTED BEHAVIOR OF APPLICATION

Follow those instructions to reduce electromagnetic perturbations:

- use the shielding connection kit BMXXSP•••• (*see page 48*) to connect the shielding.

Electromagnetic perturbations may lead to an unexpected behavior of the application.

Failure to follow these instructions can result in injury or equipment damage.

Wiring Diagram

Introduction

Module BMX AMI 0810 is connected using the 28-pin terminal block.

Illustration

The terminal block connection and the sensor wiring are as follows:

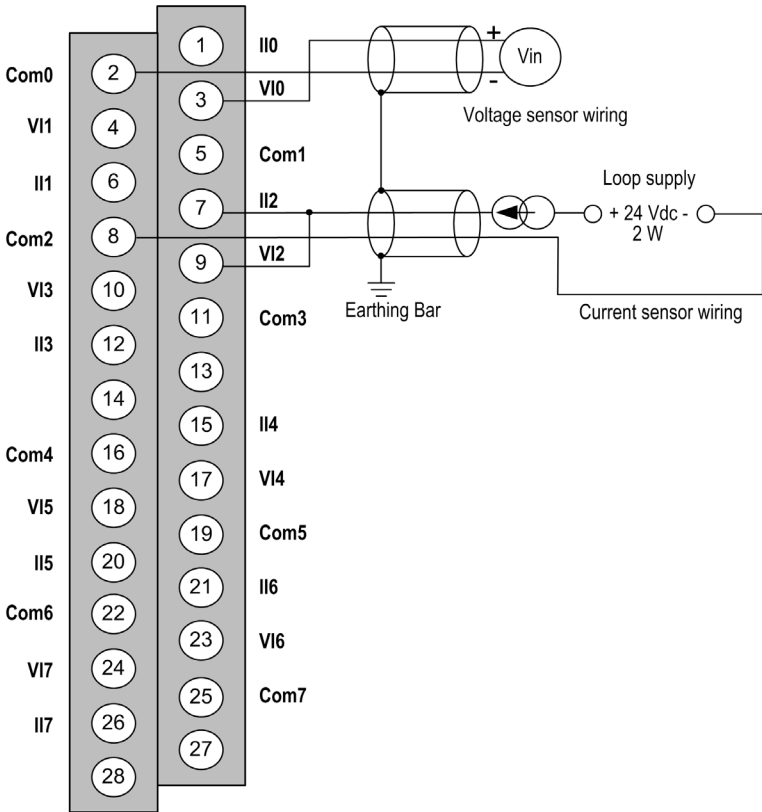

- Vix** + pole input for channel x
- COM x** - pole input for channel x
- Iix** current reading resistor + input
- Channel 0** voltage sensor
- Channel 1** 2-wire current sensor

Wiring Accessories

For rapid connection to operative parts, the module can be connected to a TELEFAST pre-wired system (see page 122).

Use of the TELEFAST Wiring Accessories

Introduction

The TELEFAST pre-wired system consists of connecting cables and interface sub-bases as shown below:

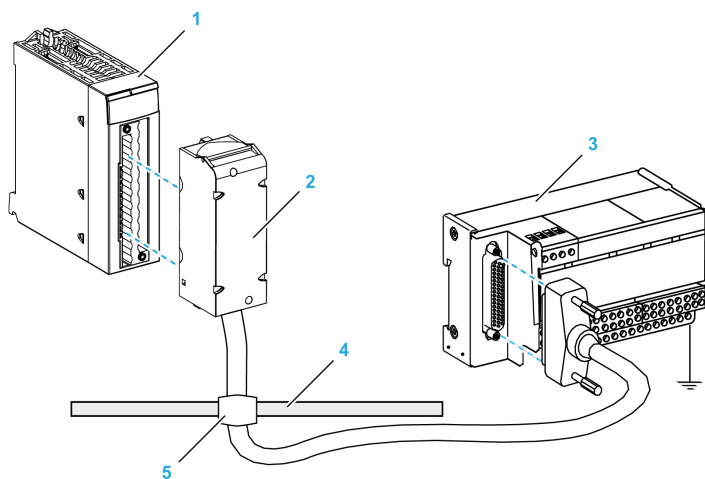

- 1 BMX AMI 0810 module
- 2 BMXFTA**0 connecting cable
- 3 Interface sub-base
- 4 Shield bar
- 5 Clamp

The BMX AMI 0810 module can be connected to the following interface sub-bases references:

- ABE-7CPA02
- ABE-7CPA31
- ABE-7CPA31E

NOTE: In case HART information is part of the signal to be measured, an ABE-7CPA31E interface sub-base has to be used in order to filter this information that would disrupt the analog value.

BMX FTA ••0 Connecting Cables

The BMX FTA ••0 cables are pre-assembled cord set, made up of:

- At one end, a compound-filled 28-pin terminal block from which extend 1 cable sheath containing 24 wires,
- At the other end a 25-pin Sub-D connector.

The figure below shows the BMX FTA ••0 cables:

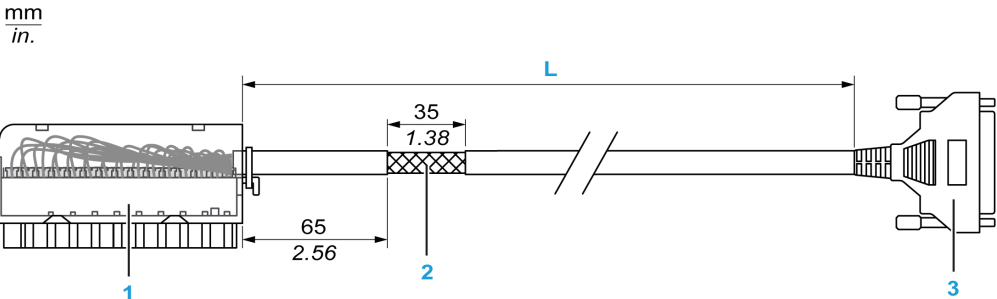

- 1 BMX FTB 2820 Terminal block
- 2 Cable shielding
- 3 25-pin Sub-D connector
- L Length according to the part number.

The cable comes in 2 different lengths:

- 1.5 m (4.92 ft): BMX FTA 150
- 3 m (9.84 ft): BMX FTA 300

The following table gives the characteristics of the BMX FTA ••0 cables:

Characteristic		Value
Cable	Sheath material	PVC
	LSZH status	No
Environmental	Operating temperature	-25...70 °C (-13...158 °F)

ABE-7CPA02 Sensor Connection

The following table shows the distribution of analog channels on TELEFAST terminal blocks with the reference ABE-7CPA02:

TELEFAST terminal block number	25-pin Sub-D connector pin number	BMXAMI0 810 pin out	Signal type	TELEFAST terminal block number	25-pin Sub-D connector pin number	BMXAMI0 810 pin out	Signal type
1	/		Ground	Supp 1	/		Ground
2	/		STD (1)	Supp 2	/		Ground
3	/		STD (1)	Supp 3	/		Ground
4	/		STD (2)	Supp 4	/		Ground
100	1	3	+IV0	200	14	2	COM0
101	2	1	+IC0	201	/		Ground
102	15	4	+IV1	202	3	5	COM1
103	16	6	+IC1	203	/		Ground
104	4	9	+IV2	204	17	8	COM2
105	5	7	+IC2	205	/		Ground
106	18	10	+IV3	206	6	11	COM3
107	19	12	+IC3	207	/		Ground
108	7	17	+IV4	208	20	16	COM4
109	8	15	+IC4	209	/		Ground
110	21	18	+IV5	210	9	19	COM5
111	22	20	+IC5	211	/		Ground
112	10	23	+IV6	212	23	22	COM6
113	11	21	+IC6	213	/		Ground
114	24	24	+IV7	214	12	25	COM7
115	25	26	+IC7	215	/		Ground

NOTE: On the ABE-7CPA02, the strap position is between pin 1 and pin 2.

+IVx: + pole voltage input for channel x.

+ICx: + pole current input for channel x.

COMx: - pole voltage or current input for channel x.

NOTE: For current sensors connected on the TELEFAST ABE-7CPA02, a strap must be made on the BMX AMI 0810 terminal block between the current input and the voltage input as illustrated below.

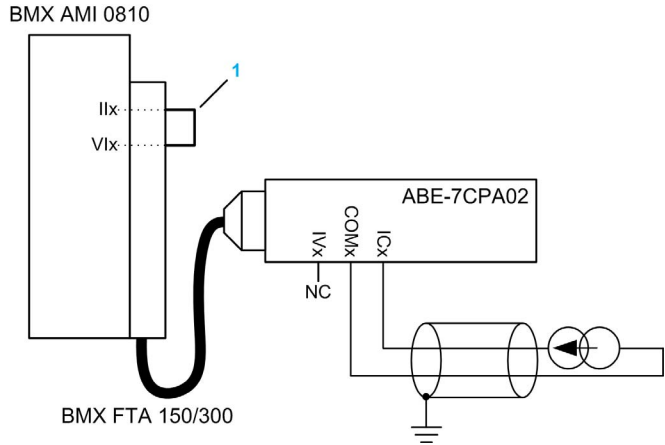

1 Strap on the terminal block.

NOTE: For the ground connection use the additional terminal block ABE-7BV10/20.

ABE-7CPA31 Sensor Connection

The following table shows the distribution of analog channels on TELEFAST terminal blocks with the reference ABE-7CPA31:

TELEFAST terminal block number	25-pin Sub-D connector pin number	BMXAMI0 810 pin out	Signal type	TELEFAST terminal block number	25-pin Sub-D connector pin number	BMXAMI0 810 pin out	Signal type
1	/		Ground	Supp 1	/		24 V (sensor supply)
2	/		Ground	Supp 2	/		24 V (sensor supply)
3	/		Ground	Supp 3	/		0 V (sensor supply)
4	/		Ground	Supp 4	/		0 V (sensor supply)

+ISx: 24 V channel power supply
+IVx: + pole voltage input for channel x
+ICx: + pole current input for channel x
COMx: - pole voltage or current input for channel x.

TELEFAST terminal block number	25-pin Sub-D connector pin number	BMXAMI0 810 pin out	Signal type	TELEFAST terminal block number	25-pin Sub-D connector pin number	BMXAMI0 810 pin out	Signal type
100	/		+IS0	116	/		+IS4
101	1	3	+IV0	117	7	17	+IV4
102	2	1	+IC0	118	8	15	+IC4
103	14	2	0 V	119	20	16	0 V
104	/		+IS1	120	/		+IS5
105	15	4	+IV1	121	21	18	+IV5
106	16	6	+IC1	122	22	20	+IC5
107	3	5	0 V	123	9	19	0 V
108	/		+IS2	124	/		+IS6
109	4	9	+IV2	125	10	23	+IV6
110	5	7	+IC2	126	11	21	+IC6
111	17	8	0 V	127	23	22	0 V
112	/		+IS3	128	/		+IS7
113	18	10	+IV3	129	24	24	+IV7
114	19	12	+IC3	130	25	26	+IC7
115	6	11	0 V	131	12	25	0 V
<p>+ISx: 24 V channel power supply +IVx: + pole voltage input for channel x +ICx: + pole current input for channel x COMx: - pole voltage or current input for channel x.</p>							

NOTE: For current sensors connected on the TELEFAST ABE-7CPA31, a strap must be made on the BMX AMI 0810 terminal block between the current input and the voltage input as illustrated below.

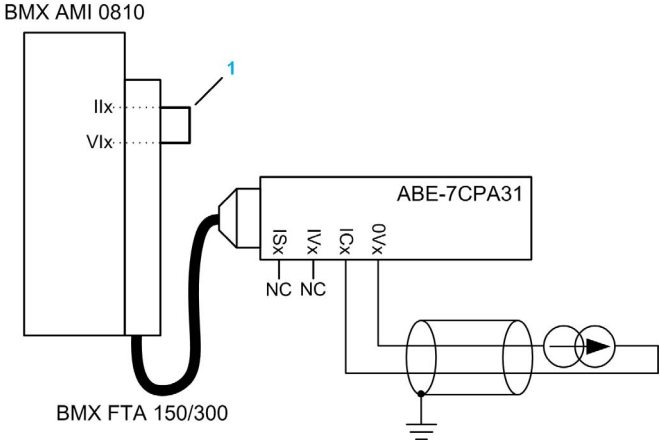

1 Strap on the terminal block.

NOTE: For the ground connection use the additional terminal block ABE-7BV10/20.

ABE-7CPA31E Sensor Connection

The following table shows the distribution of analog channels on TELEFAST terminal blocks with the reference ABE-7CPA31E:

TELEFAST terminal block number	Terminal	Signal type	TELEFAST terminal block number	Terminal	Signal type
1	/	Ground	Supp 1	/	24 V (sensor supply)
2	/	Ground	Supp 2	/	24 V (sensor supply)
3	/	Ground	Supp 3	/	0 V (sensor supply)
4	/	Ground	Supp 4	/	0 V (sensor supply)
100	/	+IS0	116	/	+IS4
101	/	T0	117	/	T4
102	/	+IC0	118	/	+IC4
103	/	0V0	119	/	0V4
104	/	+IS1	120	/	+IS5

+ISx: 24 V channel power supply
Tx: Reserved test pin for HART function, it's internally connected with +ICx.
+ICx: + pole current input for channel x
COMx: - pole voltage or current input for channel x

TELEFAST terminal block number	Terminal	Signal type	TELEFAST terminal block number	Terminal	Signal type
105	/	T1	121	/	T5
106	/	+IC1	122	/	+IC5
107	/	0V1	123	/	0V5
108	/	+IS2	124	/	+IS6
109	/	T2	125	/	T6
110	/	+IC2	126	/	+IC6
111	/	0V2	127	/	0V6
112	/	+IS3	128	/	+IS7
113	/	T3	129	/	T7
114	/	+IC3	130	/	+IC7
115	/	0V3	131	/	0V7

+ISx: 24 V channel power supply
Tx: Reserved test pin for HART function, it's internally connected with +ICx.
+ICx: + pole current input for channel x
COMx: - pole voltage or current input for channel x

NOTE: For current sensors connected on the TELEFAST ABE-7CPA31E, a strap must be made on the BMX AMI 0810 terminal block between the current input and the voltage input as illustrated below.

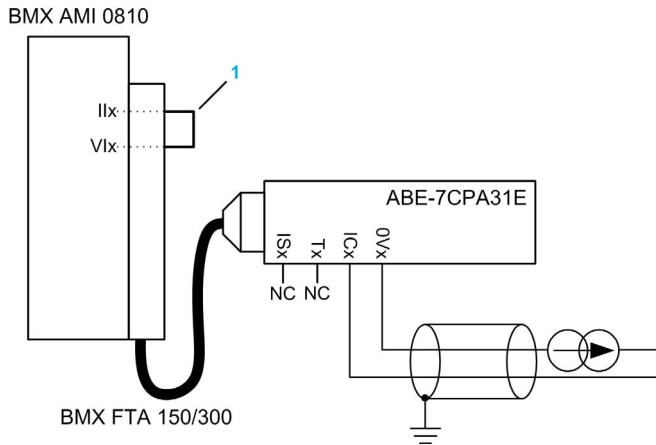

1 Strap on the terminal block.

NOTE: For the ground connection use the additional terminal block ABE-7BV10/20.